

QINSTRUMENTS

A BICO COMPANY

THE LIFE SCIENCE COMPANY

with brilliant ideas & pioneering spirit

QINSTRUMENTS GmbH





NATURE'S PERFECT DESIGN

THE CHEETAH IS THE FASTEST ANIMAL ON EARTH
& AS SUCH SYMBOLIZES OUR WAY OF WORKING:

QUICK ACTIONS AND REACTIONS, EXPERIENCE ON THE
FIELD, COMPLETE AVAILABILITY FOR OUR CLIENTELE,
AVAILABILITY OF DOCUMENTATION, TABLES, KNOW-HOW
& AMPLE KNOWLEDGE WITH THE POSSIBILITY OF
CARRYING OUT PATENTS AND STANDARDS!

QINSTRUMENTS Design Group

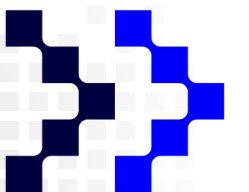

BRING PROJECT IDEAS

TO LIFE WITH OUR INNOVATION

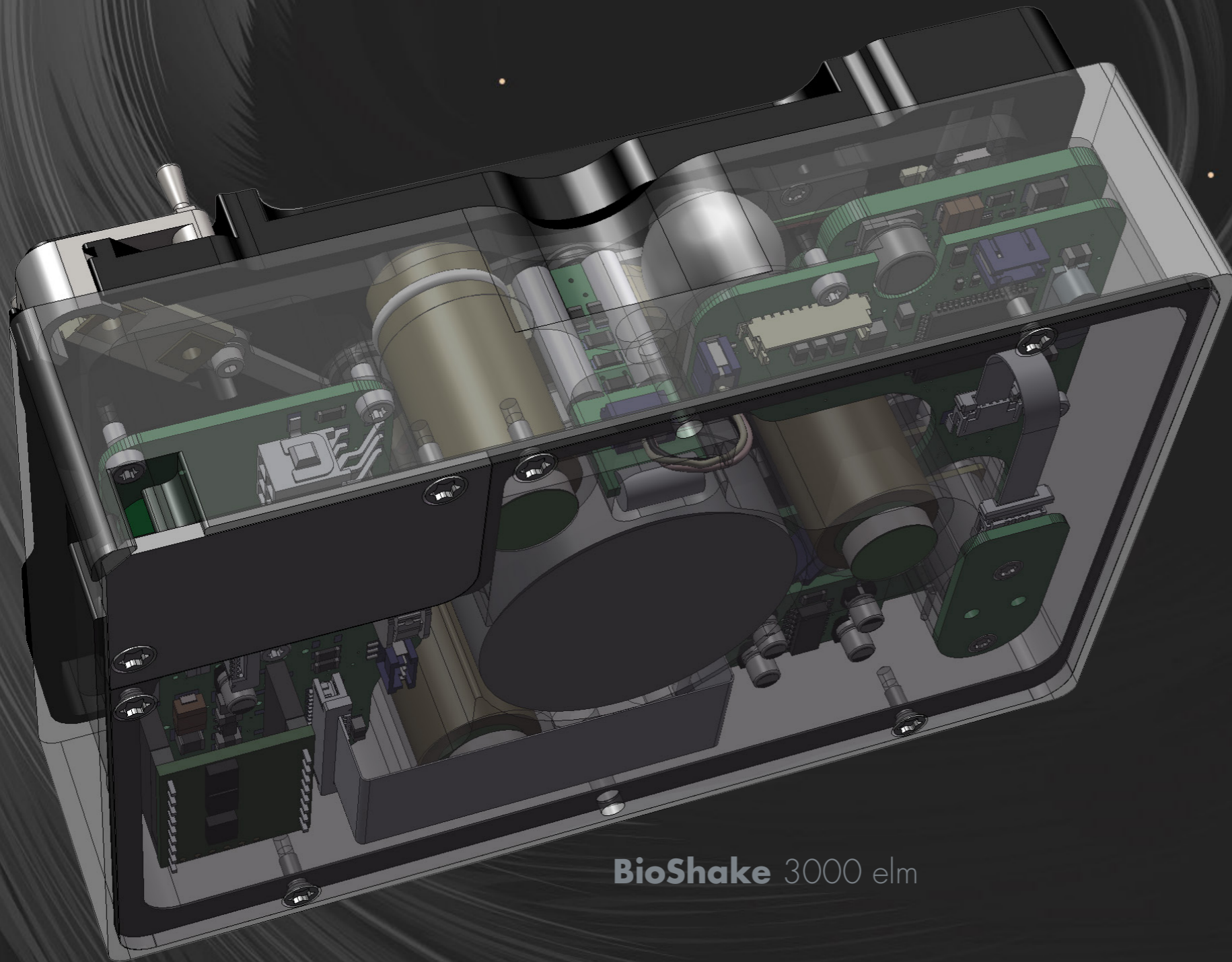

BioShake 3000 elm

NATURE

HOLDS THE KEY TO OUR
AESTHETIC, INTELLECTUAL,
COGNITIVE AND STRONGLY FOCUSED
RESEARCH & DEVELOPMENT.



BioShake 3000-T elm



WE ARE THE GERMAN
LIFE SCIENCE COMPANY
WITH BRILLIANT IDEAS &
PIONEERING SPIRIT.

GREAT GERMAN
ENGINEERS ARE THE
HEART AND SOUL OF
QINSTRUMENTS.

Who we are?

OVERVIEW

QINSTRUMENTS is an Engineering and Manufacturing company located in Jena, Germany. We design, build and market equipment for sample preparation products such as shakers, thermoshaker, heating & cooling units, centrifuges and more.

VISION

In 2003, we set out with a goal to reinvent lab preparation equipment for the automation age. Our vision was simple:

“Equip every lab with the best microplate shakers and make sample mixing a valued experience again”.

QINSTRUMENTS, established in Jena, develops and manufactures fully automated, as well as individual solutions for Life Science and molecular diagnostics.

Our company is pioneer in the development of perfect solutions for mixing and temperature control of molecular samples on robotic platforms. The product range includes well designed OEM components by providing new systems that streamline operations in each lab. We are well known for our robust products, strong customer service and flexibility to deliver custom solutions to specific applications.

Our strong intellectual portfolio consists of several own and foreign-issued patents, in the areas and methods for mixing, temperature control, centrifugation, hybridization, sample processing and sample handling.

Besides this, QINSTRUMENTS intends to develop further its technologies platforms to maintain a technological edge and a strong proprietary position.

Our customers include life-science research laboratories and drug discovery laboratories in pharmaceutical and biotechnology firms.

Accepting and adapting the changing trends and needs of the customers, our prudent company currently enjoys an impressive clientele in USA, Germany, Switzerland, UK and more.



For those who prefer technical perfection and functional design, BioShake microplate shakers are the perfect choice. High tech design, precision performance and outstanding value all characterize the BioShake laboratory units from QINSTRUMENTS, made in Germany.

OLAF SIMMAT
CEO

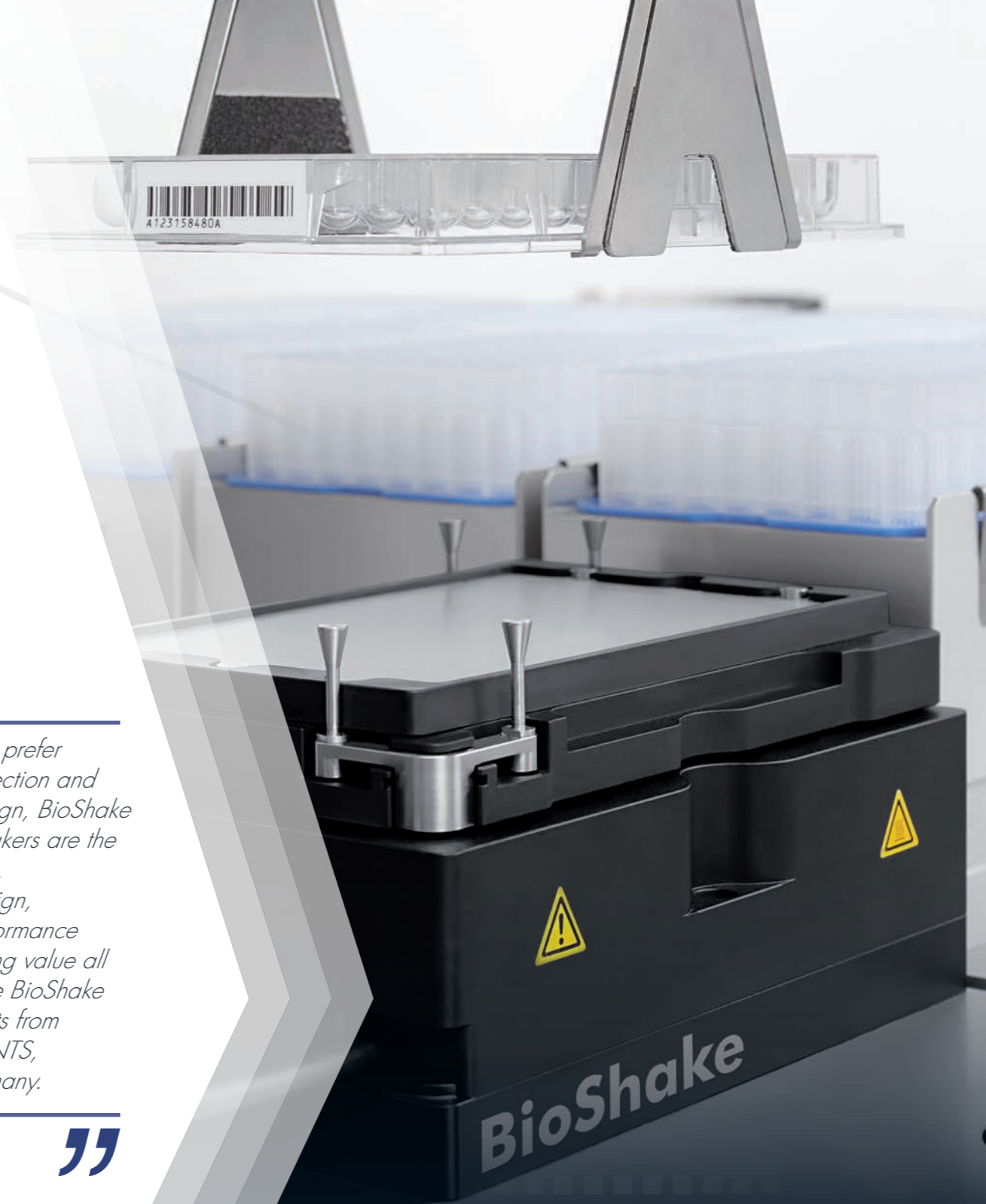

SEAMLESSLY MANAGING

YOUR SHAKER NEEDS AROUND THE WORLD

WE HAVE TAKEN THE BIOSHAKE AUTOMATION UNITS TO A WHOLE NEW LEVEL WITH FEATURES THAT GO FURTHER.

HIGHLY IMPROVED ACCURACY, INTERNAL ALGORITHMS & OPTIMIZED SENSORS ENABLE SMOOTH OPERATING WITH LONG LIFETIME.

AVAILABLE ALL OVER THE WORLD.

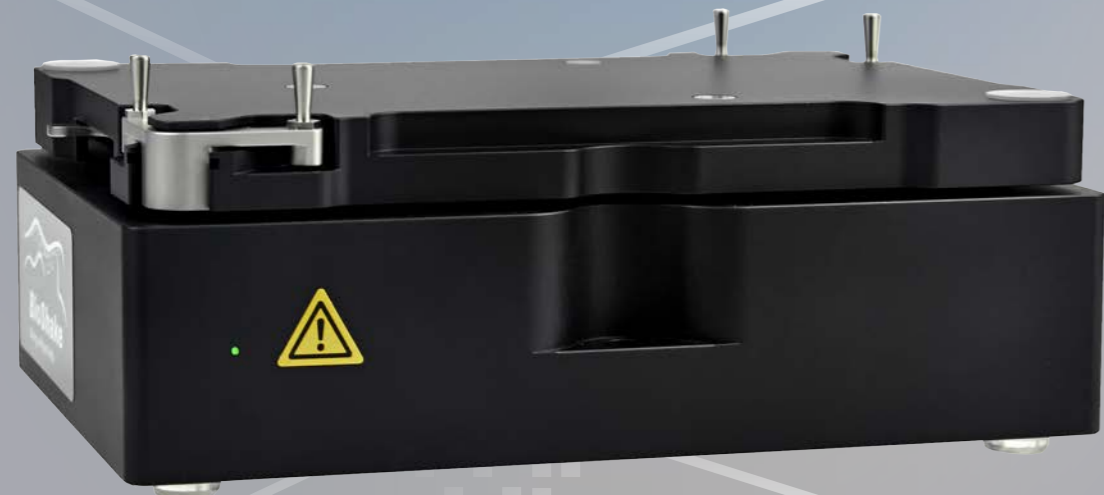

BioShake

ENHANCED TECHNOLOGY

- > Planar orbital motion
- > Speed up to 5,000 rpm
- > No noise, no vibrations
- > ZERO positioning
- > Accurate temperature control
- > Heating up to 100 °C
- > Unique edge locking
- > First-class aluminium housing

No design mixes better.

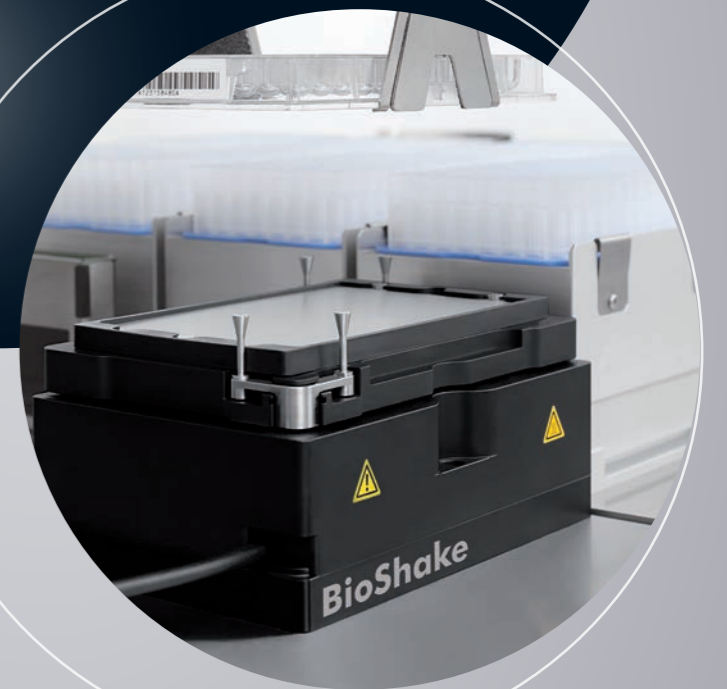

EASILY INSPIRE YOURSELF THROUGH OUR BIOSHAKE

Our BioShake innovations define the shaker standard in terms of compactness, speed, quietness, and precision.

To mix the samples they love, to discover and experience new things they never knew existed, and to appreciate it all with the highest quality.

We're constantly looking for ways to improve the experience – with new products, new software and continually investing in ways to provide our customers the best experience possible.

GLOBAL ESTABLISHED PRODUCTS

QInstruments is an internationally respected manufacturer of application-oriented laboratory instruments. Our instruments have been used for 15 years worldwide for sample preparation and lab automation in industry and research laboratories.

Trust QInstruments quality made in Germany, our experience and our service.

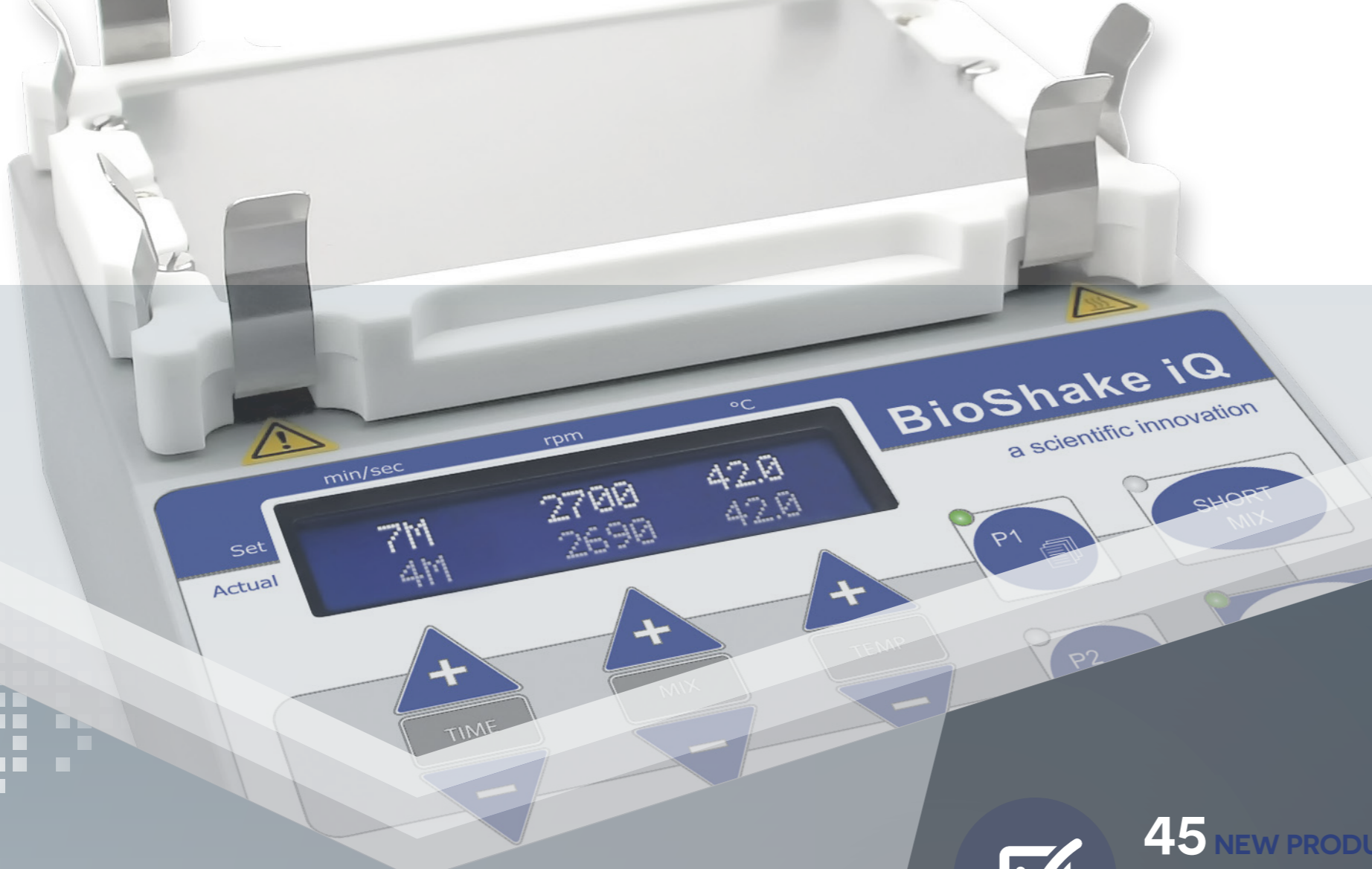

DISCOVERING OUR UNIQUE CREATIVE INSTRUMENTS

TRULY ELEGANT DESIGN INCORPORATES
TOP-NOTCH FUNCTIONALITY INTO A
SIMPLE, UNCLUTTERED FORM.

MADE IN GERMANY



 **45** NEW PRODUCTS
LAUNCHED SINCE 2003

 **1245** HAPPY CLIENTS
MEAN THAT WE HAVE
DONE A GOOD JOB

 **37** COUNTRIES
SERVED FROM GERMANY
ACROSS AMERICA, EUROPE
& ASIA

“THERE IS NO DESIGN
WITHOUT DISCIPLINE.
THERE IS NO DISCIPLINE
WITHOUT INTELLIGENCE.”

PERFECT
SOLUTIONS.

PERFECT
DESIGN.

PERFECT
LAB DAYS.

HIGH-END SHAKER

TO FIT EVERY LAB & ROBOT



MIXING ON THE RIGHT FREQUENCY
SAVES TIME & MONEY.



TECAN FLUENT™
REFERENCE PARTNER PROJECT

FEW THINGS ARE DESIGNED WELL.
EVERYTHING IS DESIGNED.

OEM DEVELOPMENT

WE ARE YOUR COMPETENT PARTNER
FROM DEVELOPMENT TO SERIES PRODUCTION.

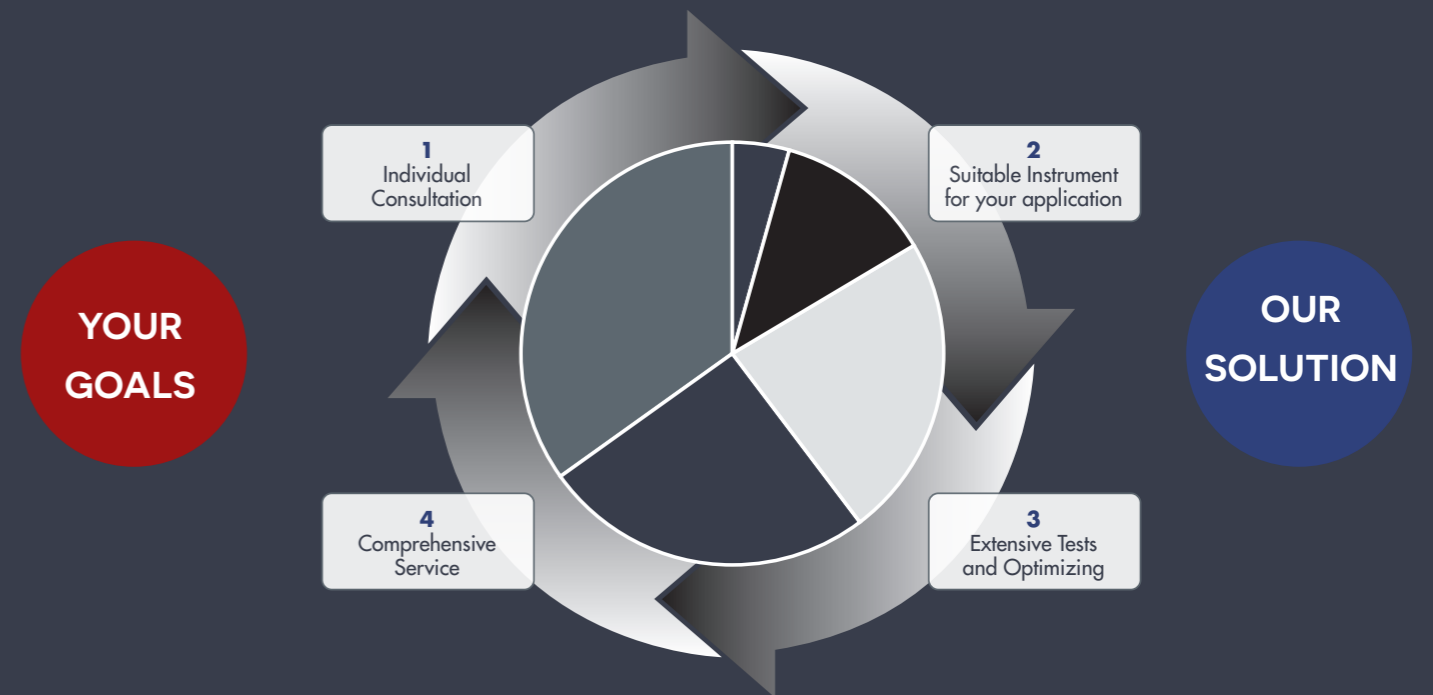

The development of new automated applications in labs and diagnostic fields are unbelievably dynamic. QInstruments aim is to develop secure solutions for automation systems that use these applications, in close cooperation with OEM customers, system integrators, and other partners.

We provide our customers and partners with individual applications or end-to-end solutions that suit their every day need.

- > Design studies
- > Development of article designs
- > Design of thermal concepts
- > Calculation and simulation
- > Creation of electronic circuits
- > Functional programming
- > Customizing and optimizing of applications
- > Prototyping
- > Series production
- > Reliability tests
- > CE and IVD approval

MADE IN GERMANY

All QInstruments devices of the BioShake series are manufactured exclusively in Germany and labelled with „CE“ and „Made in Germany“.
It guarantees a very high product quality and is internationally protected.



THE QUALITY LABEL MADE IN GERMANY MEANS TO YOU:

- Years of trouble free operation.
- The sealed housing to protect mechanical and electronic components increases the lifespan of 10 years on average of well maintained equipment.
- All units are designed for continuous 24 hour unattended operation when utilizing sound scientific methods.
- To prevent laboratory fires, all units feature an over temperature circuit which switches off if an over temperature situation occurs. Thermal damage to any unit is minimized or prevented, as all models come with a fire resistant aluminum housing.

2 YEARS GLOBAL WARRANTY

QInstruments warranted the models of the BioShake series an extended warranty of 2 years – as an expression of their superior quality in terms of functionality, performance, workmanship, durability and safety.



TÜV-CERTIFICATION & CE DECLARATION

Safety of the user and ease of use are clearly a priority for us. Independent investigations from TÜV services and CE certifications guarantee the highest security standards.

Each manufacturer of laboratory instruments and medical devices bear a heavy responsibility for its products. These have to comply with legal requirements and EU regulations. The products under the label Q. Instruments and BioShake be developed and produced according to applicable European directives and requirements in conformity with legal provisions, such as the WEEE/RoHS directive and product safety law (GPSG). All BioShake units are signed with CE label (Conformité Européenne), the statutory marks in Europe for product safety.

QINSTRUMENTS DEVICES MEET THE BASIC HEALTH AND SAFETY REQUIREMENTS AND APPLICABLE STANDARDS OF:

- 2014/30/EU – The Electromagnetic Compatibility Directive
- 2011/65/EU – Restriction of Hazardous Substances Directive
- 2015/863/EU amending Annex II to Directive 2011/65/EU
- DIN EN 61010-1:2020-03
- DIN EN 61010-2-010:2015-05
- DIN EN 61010-2-051:2016-02
- DIN EN 61326-1:2013-07
- DIN EN 61000-3-2:2015-03
- DIN EN 61000-3-3:2014-03
- DIN EN 50581:2013-02



SERVICE & SUPPORT

The Technical Service Staff of QInstruments provides superior sales services, technical support services and customer assistance for all aspects of lab equipment and lab automation. This assistance includes, but is not limited to, free technical support via e-mail, telephone, or personal visits.

QInstruments offers a yearly product maintenance and/or calibration service which includes a calibration certificate, traceable to national standards. Product calibrations are carried out in a controlled environment in accordance with our Quality Management System.

QUALITY MANAGEMENT

By quality we mean the expert performance, free of faults, of our products and services, with due regard for all the requirements and conditions that you may have as a customer and in a manner which is pleasant to you. Our aim is to realise this to the greatest extent possible. For this reason, a comprehensive and uniform quality management system has been established in QInstruments, which represents the basis for EN ISO 9001 ff compliant development and production, for numerous accreditations, certifications and licences.

Moreover, it is a matter of great importance that technical and personal development is ongoing, so as to enable our company to achieve its quality targets. Our personnel develop their competence by concentrating on recognising customer requirements correctly and completely and performing the services required in accordance with the customer's wishes.

Our daily contact with environmental matters has made us sensitive to the need of protecting our resources. For this reason, our quality management system has in some locations been augmented by the addition of an environmental management system. The compliance with the EG-Directive 2002/95/EC - RoHS („Restriction of the use of certain Hazardous Substances“) - is our top priority.

QUALITY CONTROL

The quality management process of QInstruments guarantees a constant quality of manufactured products. In order to realize this policy we have introduced a quality management system, that controls and evaluates all products and processes in the company and takes care of all necessary corrections and adjustments.

THE VERIFICATION OF THESE FACTS IS ASSURED THROUGH THE OPERATION OF A CONTROL & INSPECTION SYSTEM

- ID-Tracking of all parts and assemblies through bar code labels
- Batch tracking of all parts and assemblies
- Serial number tracking of all products
- Inspection of incoming goods
- Inspection during production/assembly process
- Calibrations and adjustments (automated and semi-automated)
- Life time tests
- Development of test and verification tools for temperature and mixing parameters
- QC analysis and documentation (QC database, final test reports, certificates, etc.)
- QC Audits through Key Account Customers
- Continuous improvement processes
- Safety tests and CE approvals



THE DESIGN IS **DONE**

WHEN THE PROBLEM GOES AWAY.



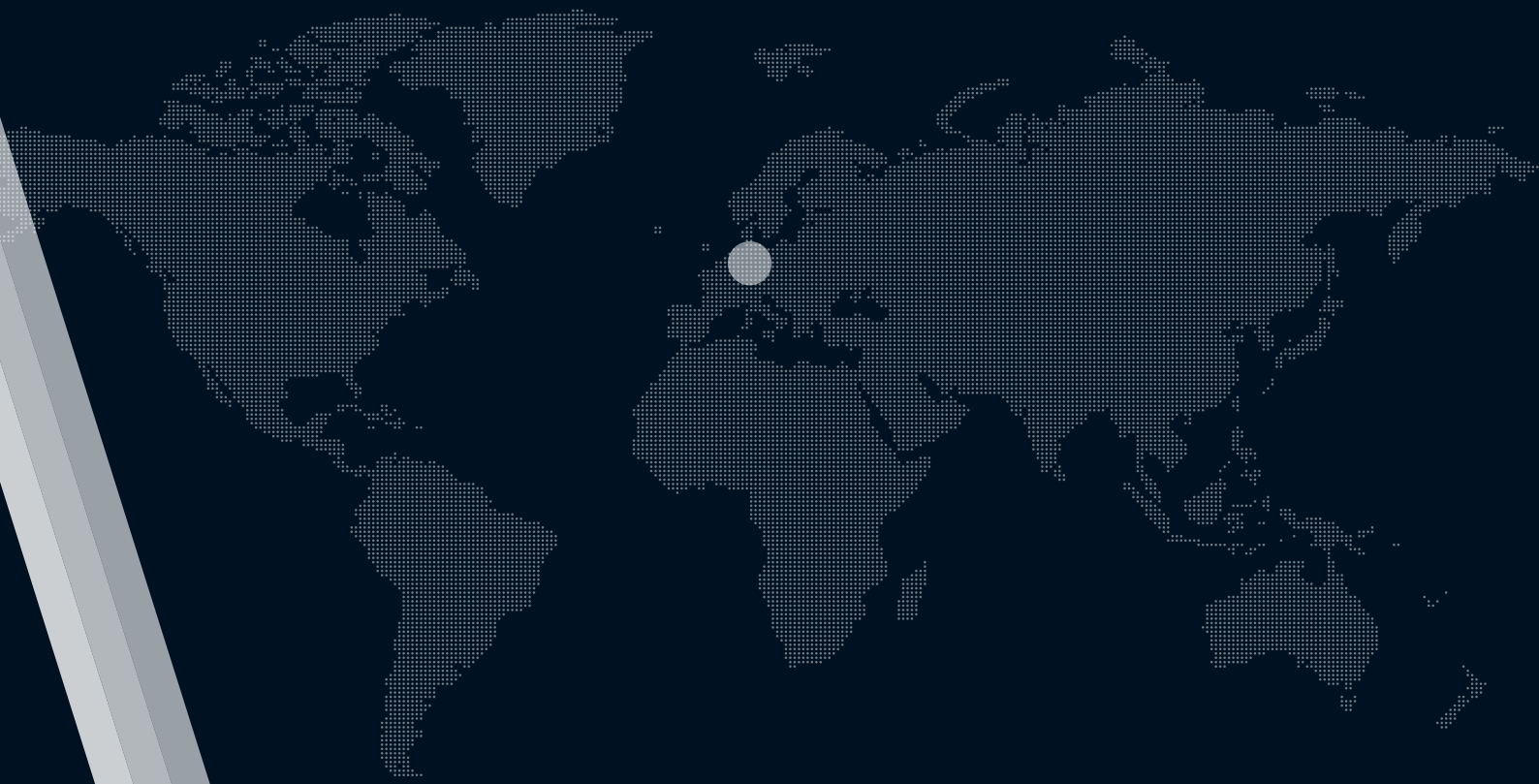

CONTACT US

TEL +49 3641 55430
EMAIL info@QInstruments.com
WEBSITE www.QInstruments.com

QIN'STRUMENTS 
A BICO COMPANY

QINSTRUMENTS GmbH

Loebstedter Str. 101
07749 Jena

GERMANY