

BioShake 3000-T elm

Operating Manual



TABLE OF CONTENTS

Table of Contents	2
1. Conventions used in this manual	3
2. Safety	3
3. Product Description	5
3.1 Intended Use	5
3.2 Features	5
3.3 Technical Specification	7
3.4 Delivery Parts	9
3.5 Device Description	10
3.6 Maintenance and cleaning	11
4. Installation	12
4.1 Device	12
4.2 Adapter	12
5. Operation	14
5.1 Introduction	14
5.2 Clamping	14
5.3 Mixing	14
5.4 Heating	17
5.5 Error handling	18
6. Accessories	19
6.1 Adapter	19
6.2 Hardware / Software	20
7. Test Software	21
7.1 QCOM 1	21
7.2 QCOM 2	21
8. Warranty	22
9. European Declaration of Conformity	22
10. Notes	23
11. Support	24

1. CONVENTIONS USED IN THIS MANUAL

Symbols used in this manual have the following meaning



WARNING: This signal word indicates a possibly imminent danger, which can result in slight to severe injuries or even death.



CAUTION: This signal word indicates a possibly imminent danger, which can result in slight to serious injuries.



CAUTION: Surface can be hot.



Information of special interest: All sections / passages that are marked with this symbol describe procedures and / or conditions that could damage or lead to a malfunction of the device. Therefore the user should pay particular attention.

2. SAFETY

The device is designed with safety in mind and no danger is known if the device is intact, installed and operated as described in the manual. Only use the device in the way as it is described in the intended use.

Independent investigations from TÜV services and CE certifications guarantee the highest security standards.

The most important prerequisites for use, operation, and safety are explained to ensure smooth operation. No warranty or liability claims will be covered if the instrument is used in ways other than those described or if the necessary prerequisites and safety measures are not observed.



The instrument may only be operated by persons who read the manual and following the safety instructions.

General safety notes



CAUTION: Electrical shock

While connected to the power the electric parts in the device can give the user an electric shock.

- ▶ Do not open the device.
- ▶ Make sure that no liquids run into the device.
- ▶ Only use the delivered power supply or one that meets all electrical specifications.
- ▶ Use a mains outlet and if required an extension lead with grounding.



CAUTION: Risk of injury due to rotating elements

Parts of device can move at high frequencies. The rotating device parts itself and mounted elements can cause injuries when touched while moving.

- ▶ Do not impede the platform motion during operation.
- ▶ Always stop device before any personal interaction.
- ▶ Never move or carry the unit while shaking.
- ▶ Operate the unit in a designated environment with appropriate safety measurements.

	<p>CAUTION: Risk of injury due to sling away of parts or liquids</p> <p>Parts of device can move at high frequencies which leads to a rotational force to all elements that are connected to this parts. If the devices is not used properly this can lead to injuries due to sling away of parts or liquids.</p> <ul style="list-style-type: none"> ▶ Ensure sound fastening of rotating elements. ▶ Only use accessories recommended by QINSTRUMENTS and standard qualitative tubes, microplates or vials. ▶ Ensure liquid vessels are closed or the liquid fill level is low enough so no liquid is spilled. Pay special attention when working with hazardous, toxic and pathogenic samples ▶ Never move or carry the unit while shaking. ▶ Wear personal safety gear (gloves, clothing, glasses, ...) and ensure the device is operated in a designated environment with appropriate safety measurements.
	<p>CAUTION: Risk of burning injuries</p> <p>Parts of the device can reach temperatures (high or low) that can lead to burn injuries if touched.</p> <ul style="list-style-type: none"> ▶ Wait until device reached room temperature before any personal interaction. ▶ Wear personal safety gear (gloves, clothing, glasses, ...) and ensure the device is operated in a designated environment with appropriate safety measurements.
	<p>WARNING: Magnetic fields can influence active medical devices (like pacemaker, defibrillator) that can cause severe injuries up to death</p> <p>Strong permanent magnets in the device can influence active medical devices (like pacemaker, defibrillator) that can cause severe injuries up to death if hold up close.</p> <ul style="list-style-type: none"> ▶ Do not open the device or conduct any maintenance tasks that require this, if you are wearing active medical device.
	<p>CAUTION: Risk of squeeze injuries</p> <p>To hold the MTP in a fixed position a mechanic is used for fixation. The mechanic moves fixation pins against the MTP. When body parts get into the movement of the mechanic they can be squeezed.</p> <ul style="list-style-type: none"> ▶ If possible use the software to control the mechanics to ensure no movement happens while interaction with the device. ▶ If the mechanism is controlled manually keep distance from the moving element of the mechanic.

3. PRODUCT DESCRIPTION

3.1 INTENDED USE

The BioShake 3000-T elm is a heater shaker used for microplates, tubes and vials for lab automation purposes. It is intended to be used in a laboratory environment by trained laboratory employees. The device is not intended to be used in environments with an aggressive or explosive atmosphere. It is required that the user ensures that not such environment is created due to the usage of the device.

The device is designed to be a module in a laboratory automation system and it is expected that it is a part of a surrounding workflow or assay. It is required that the user qualifies the performance of the device in regard to his specific circumstances of implementation and demands.

3.2 FEATURES

INTEGRATION DONE RIGHT

The BioShake 3000-T elm is optimized to seamlessly be integrated into automation platforms.

The simple and over all our devices standardized command set allows you to easily set and control process parameters and read out sensor values.

Through the integrated microelectronics no other external components or control devices are necessary. All units are designed for continuous 24 hour hands-free operation when utilizing sound scientific methods

Providing long term stable hard- and software interfaces and supporting industry standard like SiLA[®], paves the way to a superior level of lab automation. Due to the outstanding integration support we are happy to call the leading providers for lab automation our partners.

BEST IN CLASS FEATURE PERFORMANCE

Superior mixing

The BioShake 3000-T elm is designed for reliable mixing of vials, tubes and microplates. The unique and patented technique of planar orbital motion offers an ultra-efficient, 2-dimensional shaking process with a constant orbit of 2.0 mm. In that way the sample is mixed gentle but thoroughly in a fraction of time of competing systems.

Fully adjustable from **200 up to 3.000 rpm**, it guarantees optimal mixing results for samples in **96 to 384-well plates**.

Sensor-controlled zero-positioning

This patented locking mechanism locks the microplates quickly and safely, with an **accuracy of 0.1 mm**. An integrated sensor monitors this zero position and its accuracy. This ensures and simplifies the loading and removal processes and allows accurate pipetting.

ELM - Edge Locking Mechanism

The Edge Locking Mechanism (elm) is our patented answer for repeatable and accurate positioning of microplates on a robotic deck. It locks the microplates quickly and safely at the center of the module with a **variation in position as little as ±0.1 mm**. This feature makes also demanding automation workflows a breeze.

The “universal” pin design is perfect for all types of plates: from low profile to deep-well; from 96- to 1536-well.

Temperature controlled up to 99°C

Within the BioShake 3000-T elm thin, large-area heating elements and sensors are integrated. The implemented control logic guarantees an optimal heat up process. The temperature can be set **from ambient to 99°C in steps of 0.1°C** and reaches a uniformity of **temperature distribution better than ±0.5°C at 45°C** across the heating surface.

ADAPTABLE TO YOUR NEEDS Exchangeable adapters for a wide range of vial, tubes and microplates are available from stock. Perfect shaped adapters allow an optimal fit for standard tubes, lysis tubes, glass vials and other sample vessels. The **replacement of the adapters is straightforward**. Especially in applications with frequently changes of the sample container this feature provides unmatched benefits.

SECURE and STYLISH The first-class finished, stylish aluminum housing gives the BioShake 3000-T elm its essential functionality. Its sealed housing provides a high amount of security, device stability, protects mechanical and electronic components and therefore ensures a **long service-free lifetime**.

To prevent laboratory fires, all units feature an over temperature circuit which switches off if an over temperature situation occurs. Thermal damage to any unit is minimized or prevented, due to the fire resistant aluminum housing.

MADE IN GERMANY A perfectly harmonious blend of high-tech and handmade is what we strive for. "Made in Germany" has always been a recipe for success for QINSTRUMENTS. That is why 100% of QINSTRUMENTS development and production takes place in Germany.

The company focus is on human diligence combined with an environmental friendly approach to deliver outstanding constant high-quality products. For more than 20 years we have used only high-quality materials to ensure sustainable production, applied innovative thinking and undertaken research in a future-oriented way.

Join QINSTRUMENTS - "Join the Bio-convergence revolution"

3.3 TECHNICAL SPECIFICATION

Thermo-adapter plates for different labware

Description	An adapter is required for optimal temperature transfer to and/or optimal fixation of labware and needs to be purchased separately. The adapter can be exchanged by the user.
Microplates	All microplates according ANSI-SLAS format 4-, 6-, 8-, 12-, 24-, 48-, 96-, 384-, and 1536-well microplates, deep well plates, PCR plates
Tubes and Vials	0.2, 0.5, 1.5, 2.0 ml standard tubes 2.0, 4.0, 6.0, 8.0, 10.0 ml cylindrical shaped vials
Others	Custom made adapter on request

Temperature control

Temperature range*	RT to 99 °C (RT to 211.82 F) with 0.1 °C increment resolution
Temperature accuracy	± 0.1 °C
Temperature uniformity*	±0.5 K at 45 °C ±0.7 K at 75 °C ±1.0 K at 95 °C
Heating speed above RT*	~ 7 K/min (10 min from 21 to 95 °C)

* Value depends on the used thermo-adapter. Given value conditions: RT = 21 °C, Adapter = 2016-1041, 96-well PCR, adapter temperature

Mixing

Mixing frequency range	200 to 3000 rpm with 1 rpm increment resolution
Maximum frequency*	< 80 g: 3000 rpm < 120 g: 2500 rpm < 150 g: 2200 rpm < 300 g: 1800 rpm < 500 g: 1500 rpm > 500 g: 1000 rpm
Mixing orbit	constant 2.0 mm diameter
Mixing regulation accuracy	± 25 rpm
Accel. / Decel. range	1 - 30 seconds with 1 second increment resolution
Zero position	Locked zero position with ± 0.1 mm accuracy

* Feasible frequency heavily depends on load weight **and** height. **Always** start with low frequencies and iterate upwards.

ELM positioning

Description	Patented Edge Locking Mechanism (elm) for repeatable and accurate positioning of microplates on a liquid handling or automation platform. With the elm, labware can either easily be exchanged manually/automatically or it is strongly fixed in a diagonal centered position.
ELM position accuracy	± 0.1 mm

Device control

Description	Required electronic for remote control is build in the device. No external controller required.
Operation control	Remote controlled as described in the Integration Manual
Peripheral interface	EIA-232 / RS-232 interface (2 m cable with RS-232 plug-in connector) optional: USB via USB-Serial Adapters (Rec. DIGITUS DA-70156) or USB via MOXA USB-to-Serial Hub
Status	LED in front (GREEN = ok RED = error)

Electrical

Operating voltage	24 V DC Imax: 4.5 A Peff: 85 Watt Pmax: 108 Watt
Power supply	Input: 100 - 240 V AC 50 - 60 Hz Output: 24 V DC Imax: 5.0 A Pmax: 120 Watt External power supply unit (CE/UL/CSA approved, 85-264 V AC, 47-63 Hz, IEC/EN60320-1 C14 Degree of protection: IP20)
Power connection*	Prewired cable length 2 m barrel connector ID 2.5 mm x OD 5.5 mm

* Only use the device with the delivered power cord. If another power cord is used ensure the wire diameter is adequate.

General properties

Housing material	Aluminum anodized
Degree of protection	IP20 (Protected against solid objects up to 12 mm No protection against water)
Pollution degree	1 (no contamination or only dry, non-conductive contamination, whereby the contamination has no influence)
Airborne sound emission	< 70 db (A)

Operating, transport and storage conditions

Operating range	5 °C - 45 °C (41 - 113 F) 10 - 80 % RH up to 2000 m above sea level non-condensing
Floor base requirements	stable (resonance free) horizontal dry inside buildings even well ventilated and no direct exp. to sunlight
Transportation and storage	-10 °C - 60 °C (14 - 140 F) 10 - 80 % RH non-condensing

Dimension and weight

Dimensions	(W x D x H) 142 x 99 x 60.45 mm 5.59 x 3.9 x 2.38 inch
Weight	1.7 kg 3.75 lbs
Packaging size	(W x D x H) 347 x 252 x 131 mm 13.66 x 9.92 x 5.16 inch cardboard box
Packaging weight	3 kg 6.61 lbs

Drawing

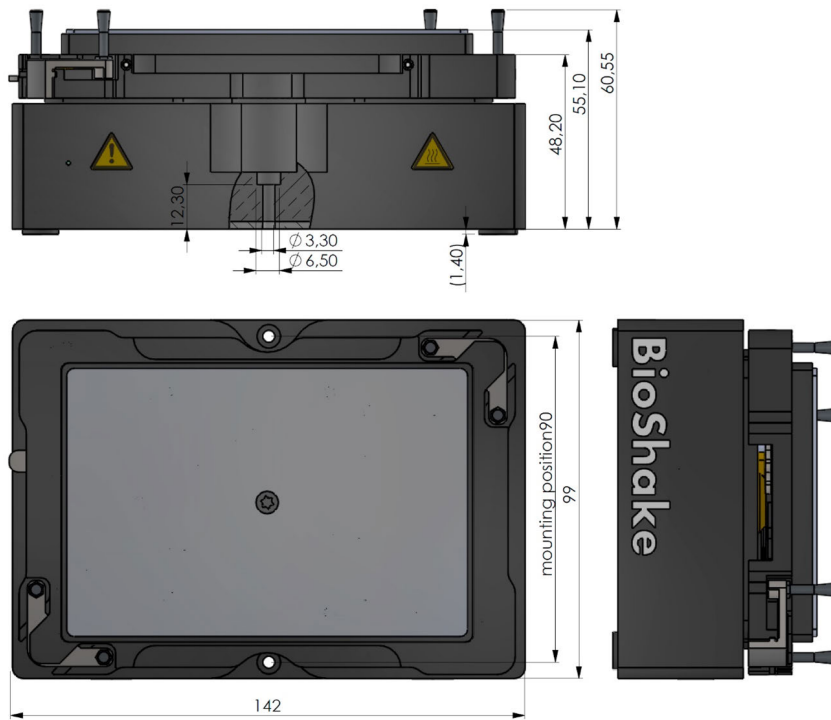

Figure 1 Technical drawing of device



Technical specifications are subject to change.

3.4 DELIVERY PARTS



Figure 2 Image showing the delivery parts

Part 1	<p>BioShake 3000-T elm* <i>incl. 2 m, 24 V DC, prewired cable</i> <i>incl. 2 m, RS-232, prewired cable</i></p> <p><i>* Flat bottom adapter is not part of the delivery and needs to be purchased separately</i></p>
Part 2	<p>External power supply 24 V DC, 120 W <i>(CE/UL/CSA approved, 85-264 VAC, 47-63 Hz, IEC/EN60320-1 C14)</i></p>
Part 3	<p>Power cords Europe & US <i>(IEC/EN 60320-1 C13)</i></p>
Part 4	<p>2x screws to mount device <i>(M3 x 18 DIN 912)</i></p>
Add. parts	<p>Calibration certificate, Operating Manual, Integration Manual</p>

3.5 DEVICE DESCRIPTION

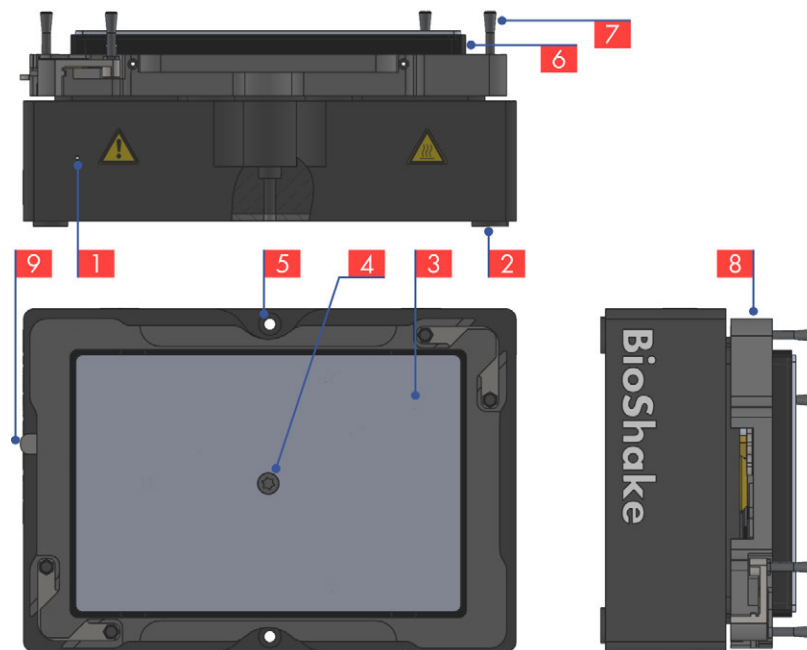

Figure 3 Device image which highlights important device elements

- 1 Status LED
The LED visualizes the operating status. Further information: ["Error handling" on page 18](#)
- 2 4x Adhesive pad
Reduce transfer of device vibrations. Depending on your integration approach they might be removed.
- 3 Heating and adapter mounting area
Further information: ["Installation" on page 12](#), ["Heating" on page 17](#),
- 4 M3 Thread to mount adapters
Further information on adapter installation: ["Installation" on page 12](#)
- 5 2x Position to mount device
Further information on device installation: ["Installation" on page 12](#)
- 6 Thermal insulation frame
- 7 4x fixing pins for automatic edge locking (ELM)
Further information: ["Clamping" on page 14](#)
- 8 Tablar - shaking desk and plate holder
Further information: ["Mixing" on page 14](#)
- 9 Hand gear for ELM

3.6 MAINTENANCE AND CLEANING

The device is maintenance-free for standard use purposes.

Cleaning should be done with a wet but not soaked cloth using a mild soap solution and water or an alcohol-based disinfectant in the following steps:

- Disconnect the power cord



CAUTION: Ignition

While connected to the power the electric parts could have a malfunction that could lead to an ignition when a inflammatory cleaning solution is used.

- ▶ Disconnect the power cord
- ▶ Do not use inflammable cleaning solution if not required

- If applicable, wait until the heading area/adapter is cooled down.



CAUTION: Surface can be hot

If the device was used right before maintenance, surfaces of the device could be hot which could lead to severe burns if not cautious.

- ▶ Make sure that the temperature at the contact surface is below +40 °C.

- When cleaning the device make sure no liquid enters the device.



CAUTION: Electronic malfunction

Cleaning solution that enters the device can damage the device electronics and lead to an electronic malfunction.

- ▶ Use a wet cloth

- Make sure all surfaces are dry before continue to use the device
- Connect device to power

If you have any questions about cleaning please contact your distributor or directly QINSTRUMENTS. Should it become necessary to repair the equipment, it should be returned to an authorized servicing agent. The equipment must be clean and free from harmful substances. Always ship the shaker well-packed, preferably in the original shipping container in order to avoid damages.

4. INSTALLATION

4.1 DEVICE

Unpack and carefully check the instrument. Report any damage or missing items to your distributor. The device should be mounted on a:

- horizontal, even surface
- sufficient stable (resonance free) table
- well ventilated location and with no direct exposure to sunlight to assure stable heating

All QInstrument devices are mounted with two screws that are part of the delivery package (2x M3 x 18 | DIN 912). The mounting point positions are the same for all devices. They have a distance of 90 mm and are on the plane that goes through the center of the mounting area.

Plug in the RS-232 into a free port of your computer. Use an USB to RS-232 converter (for example Digitus DA-70156) if required. Connect the DC cable of the device with the external power supply and plug the power cable into the wall socket.

The instrument will do a self test and the LED will turn green when the device is ready and free of errors. Now the instrument is ready to accept commands.



It is advisable to carry out a short test run to ensure that the device does not move while mixing. Further information on mixing and how to proceed are available at ["Mixing" on page 14](#)

4.2 ADAPTER

All adapters for all automation devices are mounted in the same way and use the same interface.



If the security cover plate or an adapter plate is already mounted, please remove it first!



Heavier blocks may limit the heating | mixing speed. See chapter ["Mixing" on page 14](#) and ["Heating" on page 17](#) for more details.

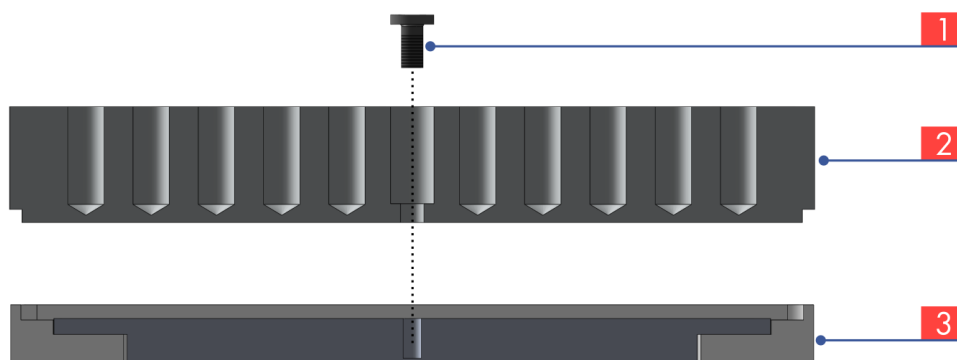



Figure 4 Illustration of adapter installation

Step	Instruction
1	Switch OFF the power supply of the instrument.  Wait until the adapter has cooled down, if applicable.
2	Remove all sample carriers (tubes, vials, microplates etc.)
3	Loosen (rotate left) the middle torx screw [1] by using the supplied screwdriver (Torx size 8) and take off the current mounted adapter plate straight up and put it on a clean, soft surface.
4	Ensure the mounting area on the device and the downside of the adapter [2] are clean and particle free.
5	Insert the new adapter plate straight into the impression of the mounting area [3] and check if the adapter reached a fixed horizontal position.
6	Fix the middle torx screw using clockwise rotation  Tightening torque: 0.6 Nm Maximum screw-in depth: 4 mm
7	Ready to apply the proper sample carriers (tubes, vials, microplates etc.). Only use the fitting carriers to ensure a tight fit.
8	Turn on the power supply of the instrument.

5. OPERATION

5.1 INTRODUCTION

In the next chapters the available operations that the device is designed to execute are described. It is intended to give the user an understanding of some underlying principles and is therefore advised to be read before using the device. With the information the user should be able to reasonably evaluate how to optimally use the device and if the device is used in its given specifications.



It is required to test the device under the specific circumstances of implementation and assay demands to ensure that the expected outcome and performance is met.

All details regarding device commands, calibration operations and error codes are available in the **Integration Manual**.

5.2 CLAMPING

The Edge Locking Mechanism (ELM) is a device feature to hold SBS sized microtiter plates in place while shaking. It has two distinct states, open and close, which can be changed by the user automatically and manually.



It is always advised to use the ELM to enhance the fixation of the MTP, regardless if you are using an adapter or not.

The ELM is developed to optimally work with SBS sized MTP's. Due to the huge amount of microtiter plate variants, it might occur that a plate is not optimally clamped with the delivered standard pins. This will lead to an unreliable mixing behavior. If this is observed, do not hesitate to get in contact (see "[Support](#)" on page 24) to obtain customized fixation pins.

5.3 MIXING

Introduction

Please keep in mind that the applications, test setups and environmental conditions in which the devices are used differ immensely. This means for example that it is not always the goal to realize the most intense mixing in the fluid. This is however mostly the intention of the described activities in the following explanation. It is hereby assumed that the user has an understanding of the needs of his process and the ability to evaluate the impact of the mixing parameters. It is strongly encouraged to invest time in optimizing the mixing process. This section is also meant to sensitize the user for the amount and complexity of parameters that might have an impact on the mixing result.

It is strongly recommended to initially evaluate the desired mixing frequency. This could be done by using the pure buffer or water and raising the frequency step by step until the desired mixing behavior is observed. Using the desired liquid for this initial experiment is advised as the surface tension has a major impact on the fluid movement in the well. Depending on the buffer that is used, water could show a significantly different mixing behavior. Additionally, to the liquid movement the mechanical limits of the device are related to the mixing frequency. Overloading with inappropriate mixing frequencies will damage the device and will lead to errors.



Because the impact of all parameters can not be estimated easily it is recommended to start with a low frequency and iterate upwards towards a satisfying result.

Device parameters

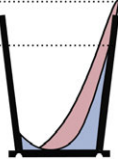
Parameter	Notes
Frequency	<p>The frequency or speed of mixing is the foremost important parameter. It defines the amount of liquid in motion in the well. The amount of liquid in motion should normally be maximized.</p> <p>If the frequency is too low no real turbulence appears in the fluid and the consequences will be bad and also not reproducible results.</p> <p>It can however happen that the frequency is too high. In this case the fluid can not follow the moving vessel and will chaotically move in the well. This will probably lead to not reproducible results and spilling of fluid is more likely.</p>
Acceleration/ Deceleration	<p>Depending on the process a slow increase and decrease in speed might be beneficial, for example to reduce shear stress on cells in fluids.</p> <p>If this is not the case it is still advised to use moderate values especially for acceleration. High acceleration can lead to an increased maximal fluid height (h_{\max} acceleration) initially, before entering the steady-state (h_{\max} steady-state). This limits the maximal frequency that can be used and raises the risk of spilling fluid.</p> <p>h_{\max} acceleration h_{\max} steady-state</p> 
Time	<p>The mixing time heavily depends on the process. Identifying the required time for a process step is crucial and is related to the settings of the other two parameters</p>

Influencing factors

The given list is not complete but only shows the common factors that should be taken into account when setting the device parameters. Depending on the process further parameters for example temperature or beads in the fluid can have a major impact.



The weight and type of load is the most important factor in regard to limiting the maximal speed of mixing. Although the device is normally not damaged if the frequency is too high a proper result will not be achieved without a constant shaking movement.

Overloading is not detected by the device.

Defects resulting from overloading are not covered from the warranty.

Param	Notes
Load	<p>Besides the actual weight of the load the height is important. With increasing height the center of mass rises, which leads to a rising force, generated from the rotating load.</p>

Recommended maximum frequencies

Max. weight [g]	Maximal mixing frequency [rpm]					
	1,000	1,500	1,800	2,200	2,500	3,000
80						X
120					X	
150				X		
300			X			
500		X				
> 500	X					

Max. speed [rpm]	Available adapters	
	Order no.	Description
3,000		Microplates with standard height according ANSI/SLAS
	2016-1021	Microplate adapter - Flat bottom standard
	2016-1022	Microplate adapter - Flat bottom, high base
	2016-1031	Microplate adapter - 96 well round bottom, type 1
2,500	2016-1032	Microplate adapter - 96 well round bottom, type 2
	2016-1041	Microplate adapter - 96 well standard PCR plate, type 1
	2016-1042	Microplate adapter - 96 well standard PCR plate, type 2
	2016-1051	Microplate adapter - 384 well standard PCR plate, type 1
2,200	2016-1064	Adapter for tubes – 96x 0.2ml
	2016-1121	Adapter for Deep Well Plate . Eppendorf® 96/1000 µl
	2016-1131	Adapter for Deep Well Plate . Eppendorf® 96/500 µl
	2016-1141	Adapter for Deep Well Plate . BRAND® 96/1100 µl U-bottom
	2016-1151	Adapter for Deep Well Plate . NUNC® / Axygen® 96/2000 µl
	2016-1161	Adapter for Deep Well Plate . Axygen® 96/0.6 ml, 96/2 ml
	2016-1171	Adapter for Storage Plate . Abgene® 96/2.2 ml, 96/0.8 ml
	2016-1172	Adapter for Abgene® 96-well storage plate 0.8ml
1,800	2016-1181	Adapter for Mega Block . Sarstedt® Megablock 96/2.2 ml
	2016-1201	Adapter for Storage Plate . Corning® 96/320 µl V-bottom
	2016-1061	Adapter for tubes - 24x 2.0 ml or 15x 0.5 ml
	2016-1062	Adapter for tubes - 24x 1.5 ml or 15x 0.5 ml
	2016-1063	Adapter for tubes - 40x 0.5 ml or 28x 0.2 ml
1,500	2016-106	Adapter for lysis vials - 35x 0.5-2.0 ml
	2016-1216	Adapter - Axygen® 48 deep well plate 5.0 ml
	2016-1216	Adapter - 24 Deep Well Plate
	2016-1060	Adapter - 15x 5.0 ml tubes
1,000	2016-1093	Adapter for Falcon® tubes . 4x 50 ml
	2016-1094	Adapter for Falcon® tubes . 12x 15 ml

Well

The well diameter plays an important role on mixing efficiency. With small diameters the surface tension has more influence on the mixing behavior and it gets harder to set the fluid in motion. Smaller diameters will need higher frequencies for proper mixing.

The well height sets the limit for the maximal fluid height while mixing. Together with the working volume it limits the frequency.

	Diameter[mm]	Height[mm]
96-Well plat	6.9	10.67
384-Well plate	3.8	8
1536-Well plate	1.5 - 1.7	4.8

Sample The sample has many properties that are influencing its mixing behavior. A great impact is related to the sample density, viscosity, and surface tension.

	Density [kg/m ³]	Viscosity [mPa*s]	Surface Tension [mNm]
Ethanol	789	1.19	22.5 at 20°C
Aqua	999.75	0.89	72.3 at 20°C
Glycerin	1260	1480	-

5.4 HEATING

Introduction

The heating feature of the device is used to heat up the sample to a defined temperature. To reach the desired temperature reliably, the following information should be used. Please be aware that the given explanations are a simplification to get a rough understanding of the subject. The actual physics and measurements behind temperature spreading and transmission in materials and over gaps, the impact of environment factors and so on are much more complex and far beyond the scope of this text.

It is important to understand that the set temperature, is the temperature the heating area [3] will reach. In most cases the set temperature will be higher than the adapter temperature [2] and the adapter temperature will be higher than the sample temperature [1]. As the sample temperature is the relevant temperature for the user, it is important to know this offset, so the temperature of the heating area can be set accordingly.

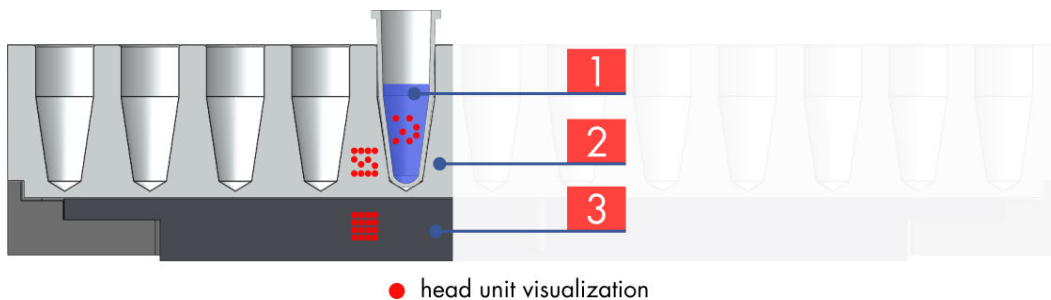

Figure 5 Visualization of heat reduction that takes place going from the heating area to the sample volume

Furthermore, the user should be aware of the time that is required to heat up the adapter and subsequently the sample. Again, it is important to realize that the temperature that is reported from the device is the temperature of the heating area and not the sample.



Because the impact of all parameters can not be estimated, it is recommended to directly or indirectly (process result) determine if the sample temperature is correct.



The efficiency to heat up the sample can/should be increased if the sample is mixed while heating.

Influencing factors

The following parameters are considered to be the main factors that are influencing the offset and required time to heat up the sample. Normally, the impact on the factors is proportional. Meaning a higher offset will also lead to an increased heat-up time and vice versa.

Parameter	Notes
Adapter	The taller the adapter the bigger the offset will be. Also the shape of the adapter is important as it defines how well the it is able to maximize the contact surface to the vessel. The more contact surface the better the heat transfer will be.
Temperature	The higher the target temperature is the bigger the thermal radiation of the adapter will be. This will lead to an increased offset.
Sample/ Vessel	The amount of sample, the vessel material, shape and if the Vessel is closed or open has an impact.

5.5 ERROR HANDLING

To provide process stability and prevent the unit from damages smart sensors for monitoring and controlling operating parameters are integrated.

Intelligent algorithms continuously track power, voltage and current from all modules and actuators, as well as a range of statistical indicators to detect suboptimal performance or events that require intervention or maintenance.

In case a failure is detected a corresponding error code will be written to the internal error list. The list can be read out to help specify the error and find the root cause.



Details on how to read out the error list and further description on error codes is available in the **Integration Manual**.

To improve the functional testing during installation and visualizing the operating status, all QINSTRUMENTS devices are equipped with a smart LED. This indication light allows a quick function test and error control. It has a green, yellow, blue or red status.

Device Status	LED color
Boot process after switching on or reset	RED
Failure-free operation	GREEN
Error detected	RED

6. ACCESSORIES

6.1 ADAPTER

QINSTRUMENTS offers high precision adapter plates with a perfect fit and optimal thermal performance for all kinds of tubes, vials, microplates, and other different disposables, from stock.

We are also offering to produce custom made adapters, that exactly meet the specifications of your sample container. You will receive your **custom shaped adapter** plate within short period.



Only use the original accessories recommended by QINSTRUMENTS. QINSTRUMENTS does not honor any warranty or accept any responsibility for damage resulting from using 3rd party accessories.

Order no.	Description
Thermo adapter for micro well plates & PCR plates	
2016-1021	Adapter for micro well plate . Flat bottom standard . e.g. Nunc® #269620, Greiner® #781101
2016-1022	Adapter for micro well plate . Flat bottom High Base . e.g. Greiner® HiBase #78407x, 78410
2016-1024	Adapter for micro well plate . Flat bottom Low Base . e.g. Aurora® storage plate, Alere ArrayStrip®
2016-1032	Adapter for micro well plate . 96 well round bottom . e.g. Greiner®, NUNC®, Matrix® plates
2016-1041	Adapter for PCR Plate . 96 well . e.g. Eppendorf twin.tec® #0030-128.672
2016-1051	Adapter for PCR Plate . 384 well . e.g. Eppendorf twin.tec® #0030-128.532
Thermo adapter for deep well plates & storage plates	
2016-1121	Adapter for Deep Well Plate . Eppendorf® 96/1000 µl . #0030-503.209
2016-1131	Adapter for Deep Well Plate . Eppendorf® 96/500 µl . #0030-501.101
2016-1141	Adapter for Deep Well Plate . BRAND® 96/1100 µl U-bottom . #701350
2016-1151	Adapter for Deep Well Plate . NUNC® 96/2000 µl . #278743, 278752
	Adapter for Deep Well Plate . Axygen® 96/2.0 ml round bottom . #P-DW-20-C
2016-1161	Adapter for Deep Well Plate . Axygen® 96/0.6 ml V-bottom . #P-DW-500-C
2016-1171	Adapter for Storage Plate . Abgene® 96/2.2 ml MARK II square well . #AB-09032
2016-1172	Adapter for Storage Plate . Abgene® 96/0.8 ml round well . #AB-0765, AB-0859
	Adapter for Storage Plate . HJ-Bioanalytik® 96/1.2 ml riplate low profile . #750289
2016-1181	Adapter for Mega Block . Sarstedt® Megablock 96/2.2 ml . #82.1972.002
2016-1201	Adapter for Storage Plate . Corning® 96/320 µl V-bottom . #3342, 3347, 3357, 3363, 3894-3898
2016-1211	Adapter for Masterblock . Greiner® 96/1.0 ml U-bottom . #78020x, 78026x
Thermo adapter for deep well plates & storage plates	
2016-1061	Adapter for tubes . 24x 2.0 ml or 15x 0.5 ml
2016-1062	Adapter for tubes . 24x 1.5 ml or 15x 0.5 ml
2016-1063	Adapter for tubes . 40x 0.5 ml or 28x 0.2 ml
2016-1064	Adapter for tubes . 96x 0.2 ml
2016-1067	Adapter for lysis tubes . 35x 0.5-2.0 ml, Ø 10.2 mm
2016-1093	Adapter for FALCON® tubes . 4x 50 ml or 2x 15 ml
2016-1094	Adapter for FALCON® tubes . 12x 15 ml
2016-1069	Adapter for glass vials . 35x 2.0 ml, Ø 10.8 mm
2016-1071	Adapter for glass vials . 35x 2.0 ml, Ø 12 mm
2016-1072	Adapter for glass vials . 20x 4.0 ml, Ø 15 mm
2016-1073	Adapter for glass vials . 20x 4.0 ml, Ø 17 mm
2016-1074	Adapter for glass vials . 20x 6.0 ml . Ø 19 mm



Figure 6 Example images of adapters

6.2 HARDWARE / SOFTWARE

Order no.	Description
2016-0200	SILA Driver for BioShake . compliant and approved driver . according SILA standard
2016-9120	USB/RS232 Converter – Digitus DA-70156 USB serial adapter USB 2.0
2016-0071	Moxa 4-port - Connects 1-4 BioShake serial devices via USB-Port to a PC
2016-0072	Moxa 8-port - Connects 1-8 BioShake serial devices via USB-Port to a PC
2016-0073	Moxa 16-port - Connects 1-16 BioShake serial devices via USB-Port to a PC

7. TEST SOFTWARE

7.1 QCOM 1

QCOM1 is a simple test tool for Windows to start using the shaker in moments and to exercise all shaker features. Plug in the RS232 cable from the single BioShake module into a free port of your computer. If it's necessary, please use a USB/RS232 converter.



Download is available at

<https://www.qinstruments.com/service/downloads/>

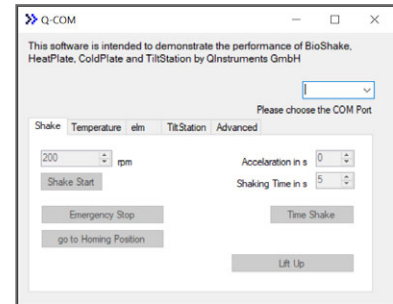

7.2 QCOM 2

QCOM2 is a small test software with a graphical user interface (GUI) to control lab automation instruments from QINSTRUMENTS, eg. BioShake, ColdPlate, HeatPlate.

The main purpose of QCOM2 is to get easy access to the unit to execute initial testing.



Download is available at

<https://www.qinstruments.com/service/downloads/>

To start the program, execute QCOM2.exe. By default, the program scans through the available COM ports and detects if a supported QINSTRUMENTS device is connected to that port. The first valid device that is found is used, the scanning process is stopped, and the program starts using the identified device. Device features will be detected at start-up, and the GUI will be adapted to the following features: mixing, ELM, temperature control.

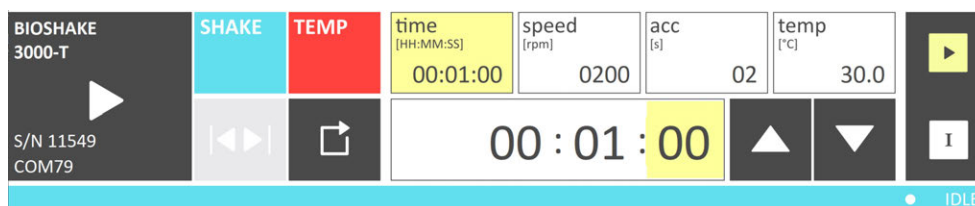

Figure 7 Image of QCOM2 GUI



For more details on how to use the software, please refer to the manual that is part of the QCOM2 download.

8. WARRANTY

QINSTRUMENTS warrants products manufactured by it to be free from defects in material or workmanship under normal use and service for a period of 2 years from date of shipment.

This warranty is specifically limited to the replacement or repair of any such warrantable defects, without charge, when the complete product is returned to QINSTRUMENTS, freight prepaid, at the address shown above. Contact the factory at the address above for a Return Material Authorization (RMA) number before returning the product.

QINSTRUMENTS shall be the sole judge of the warrant ability of alleged product defects. Products that are returned for warranty examination and that are found to be non-warrantable are chargeable and are returned freight collect. A copy of a purchase order with the amount of the charge must be received by QINSTRUMENTS, either by mail or by FAX, before any equipment is returned. Warrantable products are repaired or replaced at no charge and returned freight prepaid.

THIS EXPRESS WARRANTY EXCLUDES ALL OTHER WARRANTIES, EXPRESS OR IMPLIED, INCLUDING, BUT NOT LIMITED TO, IMPLIED WARRANTIES OF MERCHANTABILITY AND FITNESS FOR PURPOSE. QINSTRUMENTS GMBH SHALL NOT BE LIABLE FOR WARRANTY IN ANY AMOUNT EXCEEDING THE PURCHASE PRICE OF THE GOODS. QINSTRUMENTS SHALL NOT BE LIABLE FOR ANY SPECIAL, INCIDENTAL, OR CONSEQUENTIAL DAMAGES, WHETHER IN CONTRACT, TORT, OR OTHERWISE.

The buyer acknowledges that he / she is not relying on the seller's skill or judgment to select or furnish goods suitable for any particular purpose and that there are no warranties that extend beyond the description on the face hereof.

This warranty extends only to the original purchaser and shall not apply to any products or parts that have been subject to misuse, neglect, accident, or abnormal conditions or operations. Claims for damage in transit are directed to the freight carrier upon receipt.

QINSTRUMENTS will only accept parts / devices for return that do not pose a threat to the health of our staff. In particular, the devices may not have been used in Biosafety Level 3 and 4 environments or have been exposed to radioactive or radiation materials. Such devices will not be accepted by QINSTRUMENTS for return.



Please use the online form for registration of your appliance and service:

www.qinstruments.com/service/

Your completed data will serve as registered certificate of guarantee for our extended guaranteeing and will assure optimal service.

Please keep your sales slip for a possible warranty case which must be presented then. Your personal data will not be given to third persons

9. EUROPEAN DECLARATION OF CONFORMITY

The latest version is available at:

https://www.qinstruments.com/fileadmin/Article/PUBLIC/S11_ec_declaration_en.pdf

10. NOTES

11. SUPPORT

We provide a range of technical material (e.g., application notes, poster, bulletin, data sheets) that describes our products and key applications in detail. All of our technical documents are available on our web page in the corresponding product pages. Technical Data Sheet, Operation manual, 2D and 3D drawings and Software can be found in the download area of each product.

Please use the following link to our support form (<https://www.qinstruments.com/service/support/>) in case service or support for your product is needed. Please ensure to provide the serial number, as it is an important information for our support team. Direct contact via phone or email is also possible.

Online	QINSTRUMENTS.com
E-Mail	support@qinstruments.com
Phone	+49 3641 55430
Address	QINSTRUMENTS GmbH A BICO COMPANY Loebstedter Strasse 101 07749 Jena Germany

DISCLAIMER, LEGAL NOTICES AND TRADEMARKS

All document design, text, graphics, the selection and arrangement thereof and all other materials in this document are copyright by QINSTRUMENTS. QINSTRUMENTS GmbH reserves the right to modify their products for quality improvement and such modifications may not be documented in this manual. This manual and the information herein have been assembled with due diligence. QINSTRUMENTS does not assume liability for misprints or cases of damage resulting from misprints in this manual. If there are any uncertainties, please contact info@qinstruments.com.

QINSTRUMENTS is owner of numerous patents worldwide. Please respect our intellectual property.

WO2008135565, US8323588, EP2144716: Sample handling device for and methods of handling a sample

WO2011113858, US9126162, EP2547431: Positioning unit for a functional unit

WO2013113847, US10052598, EP2809436: Cog-based mechanism for generating an orbital shaking motion

WO2013113849, US9371889, EP2809435: Mechanism for generating an orbital motion or a rotation motion by inverting a drive direction of a drive unit

WO2014207243, US20160368003, EP3013480: Application-specific sample processing by modules surrounding a rotor mechanism for sample mixing and sample separation

WO002022128814A1: Laboratory apparatus comprising a fixing mechanism for fixing a slide

WO002022128809A2: Laboratory apparatus comprising a mixing mechanism for mixing a medium of a slide

Please notify us in writing, by email or mail to our designated agent, if you believe that a user has infringed our intellectual property rights. QINSTRUMENTS trademarks are recognized worldwide. Please respect our trademarks as we will vigorously protect their proper usage.

QINSTRUMENTS®, **BioShake®**, **ColdPlate®**, **HeatPlate®** (QINSTRUMENTS GmbH)

Trademarks of third parties may appear on this site when referring to those entities or their products or services. All registered names, trademarks, etc. used on this site, even when not specifically marked as such, are not to be considered unprotected by law. Any names and trademarks not specifically marked or listed are property of the respective owner.

Further trademarks used in this website and catalogs: Brand® (BRAND GmbH + Co KG), Corning® (Corning, Inc.), Eppendorf® (Eppendorf AG), Thermomixer® (Eppendorf AG), Eppendorf Tubes® (Eppendorf AG), Eppendorf twin.tec® (Eppendorf AG), Falcon® (Becton, Dickinson And Company), Greiner® (Greiner Labortechnik GmbH), MOXA® (Moxa, Inc.), NUNC® (Nunc NS Corporation), SILA Rapid Integration® (Association Consortium Standardization in Lab Automation), TECAN® (TECAN Group AG), Windows® (Microsoft Corporation).

Technical specifications are subject to change without notice. All rights reserved.