





Operating Instructions

Heating Block Thermostat HBT 100

Safety instructions

-  Ensure that fluids cannot reach cable connections or penetrate into the inside of the electrical device. Electric shock hazard!
-  Do not touch the hot plate or the heated blocks during operation. Burns hazard!
-  When using plastic vessels, do not exceed the operating temperature of your vessels.
-  Do not leave the removal rod screwed into the blocks when heating up the device. Burns hazard!



Installation and connection

- Place the device on a level, horizontal surface. A laboratory table is most suitable.
- Ensure that the power switch is set to "0". Insert the fitted plug on the enclosed power cable into the socket on the rear side of the device, and then connect the other end of the cable to the power supply. Please ensure that your supply voltage corresponds to the operating voltage stated on the type plate.

Operation

Insert the blocks into the device. Please insert the first block at the position where the sensor pin projects out of the heating plate. All blocks have boreholes for this purpose on their undersides. You can use the removal rod as an aid for inserting the blocks, after previously screwing it into the tapped hole on the upper side of the block. Remove the removal rod before heating up.

We recommend inserting blocks into all the positions in the device, as this is the only way to achieve optimal temperature precision.







Block with removal rod

Now switch the device on at the power switch.

Setting the nominal temperature

- Press the "Temp" key
- Set the desired temperature with the aid of the cursor keys. The current value appears in the left-hand display. The display is in °C. The nominal temperature can be set in steps of 0.1 K up to a max. of 100°C.
- Accept the set nominal value by pressing the "Temp" key again. The nominal value remains stored even after the device has been switched off.

With the acceptance of the value, the device begins to heat up to the set temperature. The LEDs on the left of the display have the following significance during the heating and control phase:

- Yellow LED : Heating function
- Green LED : Nominal value reached (± 0.5 K)
- Red LED : Nominal value exceeded
- Red LED : Nominal value not yet attained

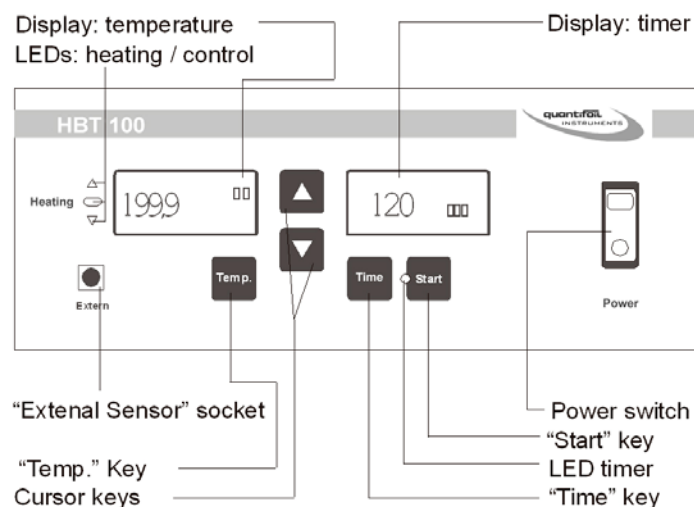

Temperature indicator

When the device is in operating mode, the left-hand display shows the actual temperature of the blocks. Press the "Temp" key to query the nominal temperature.

The display then switches to the nominal value. If you do not now set a new nominal temperature, the display automatically switches back to the actual value after 10 seconds.

If the external temperature sensor is used, this display shows the current temperature at the external sensor instead of the actual temperature of the block. Irrespective of this, the block continues to be regulated to the set nominal temperature.

Operating Instructions

Short period alarm function

The short period alarm is useful if test vessels or blocks are to be removed from the device after a limited period of time. The time after which the acoustic signal sounds is set as follows:

- Press the "Time" key
- Set the desired time with the aid of the cursor keys. The value appears in the right-hand display. The display is in minutes. The time can be set in steps of 1 minute up to a max. of 120 minutes. Store the set value by pressing the "Time" key again.
- Start the timer at the desired time by pressing the "Start" key. The LED in the "Start" key flashes while the timer is running, the minutes are counted down in the display. An acoustic signal sounds when the time has expired. Pressing the "Start" key again restarts the timer.

The short period alarm function can be used in two different modes. Depending upon the selection of parameters P1 (1 or 0), the heating and control either switch off or do not switch off after the time has expired and the acoustic signal has sounded. When the heating has switched off, the LEDs displaying the control status are also switched off. Press the "Start" key to reactivate the heating and control. You have to press the "Start" key a second time in order to restart the short period alarm.

Parameter input

Additional functions can be set by inputting parameters. You reach the parameter levels by pressing the "Temp" and "Time" once or twice simultaneously. The parameters are changed with the cursor keys. The entries are accepted by pressing the "Start" key.

- P1: Switching function of the timer
= 0 - Timer has no effect on the heating function
= 1 - Timer switches the heating off after the time has expired
- P2: Offset correction
Input of a positive or negative offset value for correcting the actual value, input between - 10K and + 10K in steps of 0.1K.
Only correct the offset when there are differences between the block temperature and the actual temperature of the display (at room temperature).
The new device is optimally calibrated in the factory.

Removing blocks

Please use the removal rod to remove blocks from the device. Screw it several turns into the tapped hole on the upper side of the block and lift it out. Hot blocks must be placed on fire-resistant surfaces. Please do not leave the removal rod in the blocks when heating up, burns hazard!

Care and maintenance

Do not use any aggressive cleanser for cleaning the external surfaces of the casing; ethanol is the best substance to use. Clean the undersides of the heating blocks and the surface of the heating plate on each occasion before the blocks are inserted. This guarantees short heating up times and good precision.

Notes

- If you do not need to change your blocks frequently, you can attach them to the heating plate. This enables you to achieve even shorter heating up times and even better temperature precision. This is done with the aid of the fixing screws and hexagonal key supplied.
- Please note that hot blocks may require several hours to cool down. Remove the blocks from the device in order to speed up the cooling down.

Scope of delivery

- Metal block thermostat
- Power connection cable
- Fixing screws for blocks
- Hexagonal key
- Removal rod

Accessories

- Aluminum blocks with additional boreholes for external temperature probe in addition to boreholes for fixing blocks to the hotplate
- Special blocks on request
- Optional: hard coating of blocks
- External temperature probe with Pt100 type A
- Block removal rod
- Fixing screws for blocks
- Hexagonal wrench for fixing blocks

Type	Order-No.
Block for 24 Tubes Ø 10mm	730
Block for 24 Tubes Ø 12mm	731
Block for 12 Tubes Ø 16mm	732
Block for 12 Tubes Ø 19mm	733
Block for 40 Eppendorf tubes 0.5ml	734
Block for 24 Eppendorf tubes 1.5ml	735
Block for 24 Eppendorf tubes 2.0ml	736
Block without boreholes	737
External temperature probe with Pt100 Type A	740
Block removal rod	741
Fixing screws for blocks	742
Hexagonal wrench for fixing blocks	743

Technical information

Number of blocks:	2
Temperature range:	room temperature ... 100°C
Temperature constancy:	± 0,1K
Heating time to 100°C:	about 15min
Control:	Microprocessor control
Settings:	digital via short travel keys
Display:	4-digit, LCD
Time control:	4-digit, LCD
Timer signal:	acoustic
Device dimensions <i>WxDxH</i> :	240x280x110mm (without feed)
Block dimensions <i>WxDxH</i> :	78x115x49 mm
Nominal voltage:	230V, 50/60Hz (spec. voltage on request)
El. heating capacity:	500W